BOTTARO WEIGHING SYSTEMS

Via G.Marconi 24050 , Grassobbio BG , Tel 035/525681 Fax 035/525689 www.bottaro-bilance.it



WEIGHING INSTRUMENT

MB02

Instructions for use

Document N°: M02P

This publication may contain information with typographic errors. Corrections will be included in new editions of the publication.





Edition dated 26/02/2014- Rev. "0"

Table of Contents

1.	INTRODUCTION	2
1.1	UNINTENDED USES	2
1.2	SAFETY	3
1.3	CARE AND MAINTENANCE	3
2.	TESTING AND INSTALLATION	4
2.1	Testing and storage	4
3.	INTRODUCTION	5
3.1	Description	5
3.2	LED indicators	6
3.3	List of selectable functions	7
4.	USING THE TERMINAL	8
4.1	Message on startup	8
4.1.1	Displaying 1/10 e	8
4.1.2	Multi-division function (MD)	9
4.1.3	Multiple range weighing function (MR)	10
5.	INTERFACES	11
5.1	Maxidisplay repeater device	11
5.1.1	Maxidisplay cable connection	11
5.1.2	Transmission string format	11
5.2	Input connection diagram	12
5.3	Rear panel	14
5.4	Loading cell connector	15
5.5	Metric plate location	16

Terminology

INDEX OF SOME TERMS USED IN THE MANUAL FOR EASIER CONSULTATION:

e	=	minimum verification division
Max	=	maximum instrument capacity
Min	=	minimum capacity
n	=	number of divisions
Load receiver device	=	scale or structure
Absolute zero Instrument	=	instrument zero calibration (+/- 1/4 e)
Sample weight	=	mass to be used as a reference for calibration
G	=	gross weight
N	=	net weight
T	=	tare weight
PT	=	Pre-set tare weight
MD	=	abbreviation for "multi-division"
MR	=	abbreviation for "multiple range weighing"
Baud rate	=	serial channel transmission speed
Frame	=	transmission format
Lights	=	indicators (e.g., LED)
etc	=	etcetera
g	=	grams
kg	=	kilograms
g1	=	gravitational acceleration at the location where the instrument is installed
g2	=	gravitational acceleration at the location where the instrument was calibrated
s###	=	minute second
ms	=	thousandth of a second
	=	note, important information or procedure
	=	attention, information or procedure that, if not followed exactly, could cause death or severe personal injury
	=	mains socket
	=	not approved function

1. INTRODUCTION

The purpose of the manual is to inform the operator of the fundamental criteria and indications for installation and correct use of the instrument using illustrations and guided examples.

The equipment must be installed only by specialized personnel who must have read and learned the contents of this manual.



"Specialized personnel" refers to those individuals with training and professional experience who have been expressly authorized by the Plant safety supervisor to install, use and maintain the terminal.

During the design phase, particular care was given in order to be able to use the instrument according to European Standards, fulfilling the requirements set forth in **L.D. 29.12.1992** no. 517 that was modified with Legislative Decree no. 40 dated February 24, 1997. It is the user's responsibility to make sure that installation is compliant with the legislation mentioned above.

The installer shall be responsible for parametrizing and calibrating it according to the specific needs while strictly following the indications above.



Tampering with the devices and use of the equipment by untrained individuals is forbidden. For this purpose, the manual must be consulted and followed whenever operating on the installation parameters.

In the event of any anomalies, contact your authorized service centre.

The information and illustrations below are updated as of the edition date shown on the cover. The technical information in this manual is the exclusive property of the manufacturer and therefore it is forbidden to make copies or share the information contained herein without the manufacturer's written authorization.

The edition date and document number identify the correspondence between the manual and the firmware installed.

According to its corporate quality policy, the manufacturer is committed to continuous improvement of its products. This could lead to changes in system components without compromising its metrological characteristics.

If there is a difference between what is described in this manual and your equipment, contact your authorized service centre.

1.1 UNINTENDED USES

Unless otherwise agreed upon during the order process, the terminal or complete system you received must not operate on moving machines or installations as it may not be possible to ensure weighing precision as specified in **EN45501**.

Anything not expressly described in this manual is to be considered improper use of the equipment.



Any attempt to tamper with the legal constraint points or change the programming parameters related to the weight data and primary indications by the user or unauthorized personnel will automatically void the warranty and will release the manufacturer of all liability regarding any injuries or damage.

1.2 SAFETY



The voltage is high enough to be life-threatening.

Maintenance and repairs done on electrical and electronic parts must only be performed by qualified technicians, after having adopted suitable safety measures.

Strictly follow the electrical rating plate on the appliance. If it is missing or illegible, request it from your authorized service centre.

Tampering with the devices and use of the equipment by untrained individuals is forbidden. For this purpose, the manual must be consulted and followed whenever using or maintaining the terminal.

The power supply for the equipment is single phase, from 230V + 10% - 15% and must be provided with an effective earth, making sure that the equipotential earth is compliant with current regulations. Make sure there is not potential difference between the earth and neutral.

Failure to earth the equipment is an incorrect and dangerous use of the instrument.

The electrical supply line must be dedicated. If already existing, use the computer power line. When there is no stable line, install a sine wave UPS or mains stabilizer.

If the terminal must be connected to other devices such as computers, etc. before hooking it up, unplug them from power.



The safety instructions contained in this manual are not intended to exclude other situations or conditions that could be hazardous. Therefore, common sense, attention and caution are important factors which cannot be made part of the machine and therefore must be followed by the authorised person who uses it and performs maintenance on it.



If the system must be installed in areas where there is a risk of explosion, this must be indicated in the order specifications. The standard equipment is not set up to operate in areas with a potentially explosive atmosphere.

1.3 CARE AND MAINTENANCE

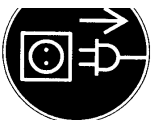

Before cleaning, the device must be unplugged from the mains.

Do not use harsh products (such as solvents). Use a cloth with detergent. Avoid liquid infiltrations in the instrument. Dry with a soft cloth.

If the operating safety of the device is no longer assured, immediately shut it off, unplug it from the mains, store it in a safe place and contact your authorized service centre. This could occur in the following situations:

- The device shows visible signs of damage or tampering.
- There is a visually obvious malfunction.
- The device was stored for a long time in unsuitable conditions.

2. TESTING AND INSTALLATION

2.1 Testing and storage

Each instrument produced and inspected is subjected to testing in order to ensure a functioning product with long life and, if provided, legalized by an official from the Notified Body.

- Upon receipt of the instrument, check for any damage that may have occurred during transport.
- Carefully unpack the instrument. Keep the original packaging for any later transport or movement.
- Store the instrument on a flat, solid and protected surface where there are no extreme changes in temperature and humidity and where it is safe from possible tampering by unauthorized personnel.
- Do not stack objects on it.
- Caution is recommended when handling the instrument.



Store the instruments as they were received. Do not stack pallets or any other type of object on it.

3. Introduction

3.1 Description

The instrument is an analogue to digital converter for loading cells built especially for an industrial environment. Therefore its features allow operation in harsh conditions.

The instrument satisfies the requirements in International Recommendation EN45501.

For greater safety, the instrument is equipped with automatic tests and a diagnostics program that gives the type of error.

It comes with either a table, wall or rack container. The control panel is splash proof with tactile sensation keys. The visor is highly visible. Some information is highlighted with separate lighted indicators.

It is equipped with EMI/RFI radio frequency filters and optical isolation to ensure operation in harsh environments.

The specific part of analogue / digital conversion is controlled with an integrated single - chip, suitably interfaced to the microcontroller.

The type of conversion used is cascaded DELTA SIGMA modulation (2 channel). All gain adjustment and zero filter functions are digitally controlled.

All electronic boards and instrument components ensure high quality.

It can be connected to any OIML R60 certified loading cell and is approved for single scale operation.

The instrument can be used individually or combined with other industrial equipment for various uses, some of which are described below:

- Weighing road and rail vehicles
- Detecting weights within production lines
- Weighing various products with different bench scale solutions (at floor level or elevated)
- Weighing in automatic loading and/or dosing systems.
- Weighing suspended loads (aerial weighing in the food industry, etc.)
- Determination of mass for calculating a toll, fee, tax, bonus, penalty, remuneration, indemnity or similar compensation, to determine price based on weight for direct sale to the public and for determining other factors such as the quantity, parameters and characteristics related to mass.
- Combination with data acquisition systems and computers
- Management of coordination devices for weighing operations
- Network connections for data transfer
- Handling systems
- With devices for automating the scale operation through automatic material handling.

3.2 LED indicators

1: Stable



This is on when the stable indication conditions are met as per parameters P06 and P07.

2: Central zero



This is lit in the interval around zero from $-1/4 e$ to $+1/4 e$.

3: Min



This is lit when the gross weight is negative or between 0 and 20 e reduced to 5 in applications for determining a transport fee.

4: Non metrological data symbol



When lit, the data shown is not bound to metric verification.

3.3 List of selectable functions

Zero Key - Zeroing device

Pressing the **ZERO** key for two seconds will zero out the weight indicator with a precision of 0.25 e. When the key is pressed, the gross weight displayed will be acquired as the new zero value as long as the following conditions are met for 1 second:

- a) stable indication
- b) gross weight **less** than $\pm 2\%$ (subsequent zeroing) of the **F.S.** around the calibration zero point. If out-of-range, the display will flash for 3 seconds.
- c) no tare device is in operation

Please note: If the requirements above are not met, the display will show E n E. The zero value acquired will not be saved in the event of a power outage.

← Key - Tare acquisition

Place the tare that must be acquired on the scale and wait until the value stabilizes.

When the  key is pressed, the gross weight displayed will be acquired as the tare weight as long as the following conditions are met for 1 second:

- a) the indication must be **stable**
- b) the value must be **greater than or equal to 1 e.**
- c) the value must be **positive**
- d) the value must be **less than the F.S.**
- e) the preset tare device must not be in operation.

If points **b**, **d** and **e** are not met, the "Tare no" error message is displayed. When the weight is unloaded the weight removed will be shown with the minus sign

With the multiple range weighing (MR) function, upon automatic switching to the higher weight range, the tare division value will be compared automatically to the division related to the range obtained.

Please Note: the tare value acquired will not be saved in the event of a power outage.

GROSS/NET - Change display key

If there is a tare weight present, pressing the key will display the gross weight. When the key is pressed again, the previous net weight will be displayed.

- Save tare key

If there is a tare weight present (previously acquired using the  key), pressing the key mentioned above will save it so that all weights that follow are performed removing the previously set tare weight.

To remove the tare from the memory, just press the

 key again.

4. Using the terminal

4.1 Message on startup

The **software version** and the **use ZONE** will be displayed (for about two seconds).





U G A

4.1.1 Display 1/10 e

M

The instrument has a device for which the 1/10 division can be displayed as long as the related parameter is enabled.

Once the terminal has been programmed in this manner, during normal display the last digit on the weight display (on the right) will remain off.

Pressing  and  at the same time activates the procedure and the last digit is lit up and is the value of the 1/10 division.

This display will remain active for about 5 seconds after which the terminal will automatically return to the normal weight display.



This function is only possible if it was enabled in the setup program.

4.1.2 Multi-division function (MD)

Through **internal programming** you can enable the multiple division function in two weight ranges each with a minimum verification division.

The instrument, whether loading or unloading, automatically updates the verification division to the value related to the partial weighing range.

The drawing below illustrates the function for a multiple division application in three weight ranges:

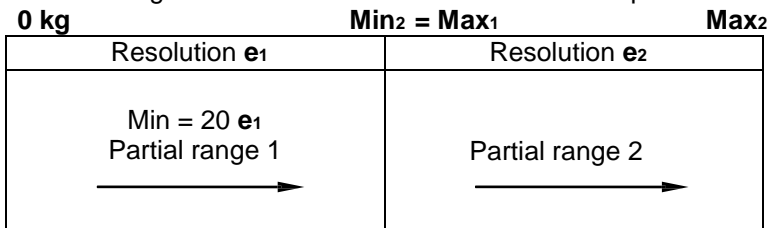

Where **Max₁** = maximum capacity of the partial weight range defined by the division **e₁**. **Min₁** = minimum capacity of the partial weight range defined by the division **e₁**.

Tare acquisition

When a tare weight is acquired, the weighing always starts from the lower range, that is the one with the lesser verification division.

A self-weighed tare value can be equal to **Max_r** minus **e₁**.

Example: 3000 kg scale with two division ranges:

Partial range 1: 0 ÷ 1500 kg **e₁** = 500 g

Partial range 2: 1500 ÷ 3000 kg **e₂** = 1000 g

If a tare of 2500 kg is acquired, weighing starts with the division **e₁** (500 g), with **Max₁** equal to 1500 kg. Since the full scale is 3000 kg, in this example, since the first range of 1000 kg is exceeded, only 500 kg remains in the second range (**e₂** = 1000 g) for arrive at full scale: 3500 kg (tare) + 1500 kg (first range) + 1000 kg (second range) = 6000 kg.

The situation is illustrated in the figure below.

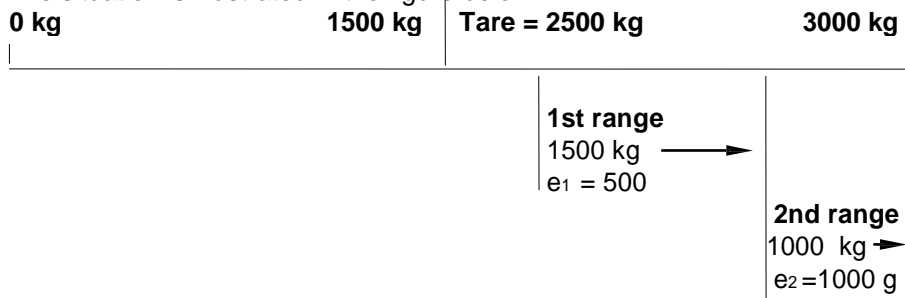

If in multiple divisions the operating range is not signalled by acquiring a tare, it always restarts from the first weighing range.

Entering tare weight (preset tare)

If a tare is entered, the maximum value of the tare may not be greater than the **Max₁** value, which is the maximum capacity of the first partial weighing field.

5. Interfaces

5.1 Maxidisplay repeater device

The terminal can be programmed to control the *Maxidisplay repeater* device through a RS 485 serial connection. This selection is made in the SERIAL PAR. menu under general programming that can be accessed after pressing the setup key.

The parameters set by the manufacturer on the MB 01 (version 1.14) terminal are as follows:

APPLICATION PARAMETERS	Description
Baud rate serial channel RS 485	9600 baud rate
Data format	8/none/1

5.1.1 Maxidisplay cable connection

MAXIDISPLAY			side MB01 EQUIPMENT side	
9 way male			9 way female SERIAL 485	
Pin no.	Description		Pin no.	Description
8	RXD	←	8	TXD -
6	RXD +	←	6	TXD +

Please Note: on the maxidisplay board, the J3 jumper must be between 1 and 2

5.1.2 Transmission string format

The transmission string on the 485 serial channel can be transmitted only in **Continuous** mode and only on a 485 serial channel that is enabled for the Maxidisplay connection. The 11 digit string transmitted is as follows:

Num. of Digits	Description	meaning
1	\$	Start char
2	space	
3	1	
4	1 dig weight	
5	2 dig weight	
6	3 dig weight	
7	4 dig weight	
8	5 dig weight	
9	6 dig weight	
10	7 dig weight	
10	CR	End char

5.2 Input connection diagram

The terminal has two inputs that can be associated with various functions to be selected from among: zeroing, tare acquisition, single printout and totals printout and are set in the setup area.

For proper operation 12 Vdc power supply is needed which can be external, from an external power supply as long as it is stable and without disturbances, or inside the MB01 terminal as in the attached diagram.

Any external contacts must be at normally open "NO".

DB 15 male connector

Pin no.	Output no.
1 3	input 1
2 3	input 2
1 + 2 3	input 3
3	0 Vdc
11	12 Vdc

Example of connection between MB01 weight detection terminal and external systems:

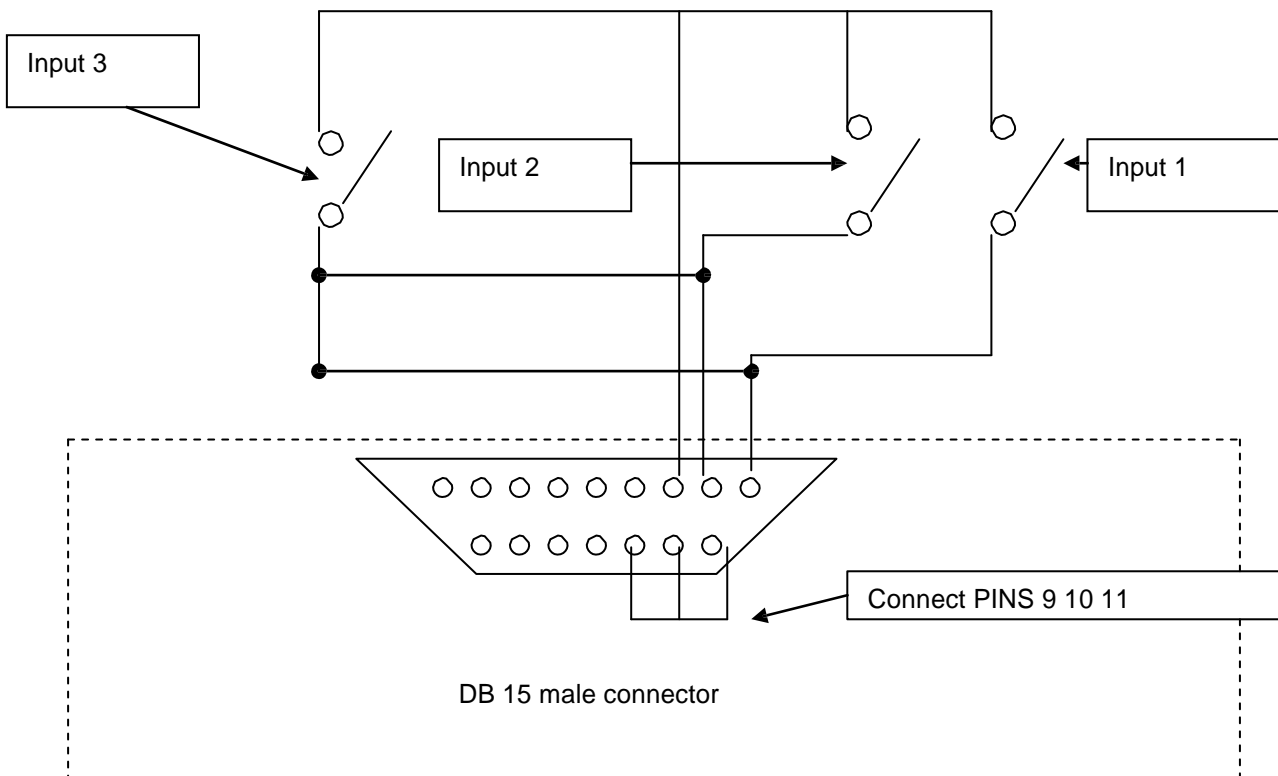

		1	2	3	4	5	6	7	8
1	SCALE ADDRESS	Set value from 1 to 31							
2	CONFIRM CE	NO	YES	-	-	-	-	-	-
3	CONVERSION TIME	Set value from 1 to 15							
4	MEDIA CONVERSIONS	Set value from 1 to 32							
5	STABILITY RANGE (e)	0	1	2	3	4	5	6	7
6	STABILITY TIME (s)	Set value from 0 to 4 (STEP 0.5)							
7	ZERO TRACKER	Set value from 0.5 to 6.0 div							
8	DISPLAY NEGATIVE	NO	YES	-	-	-	-	-	-
9	EXECUTION MODE	BENCH	WEIGH-BRIDGE	No printer	piece	Eng. unit	-	-	-
10	USE ZONE	ZONE A	ZONE B	ZONE C	ZONE SICILY 2				
11	CALIBRATION ZONE	ZONE A	ZONE B	ZONE C	ZONE SICILY 2				

Installation parameters

Installation date:

Instrument S/N

Installer:

Installing co.:

Highlight the installation parameters and attach a copy to the instrument

5.3 Rear panel

The figure shows the layout of the external instrument connection in the table version:

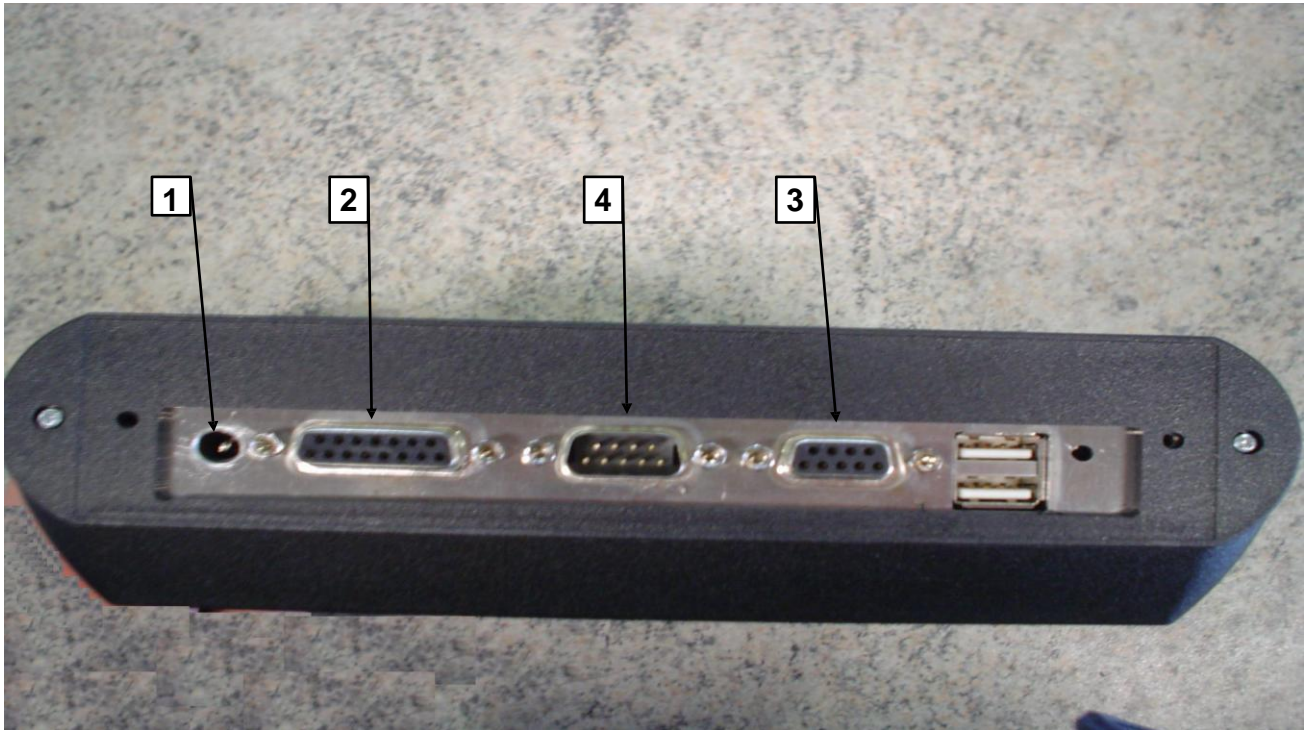

Description:

- 1 INPUT VOLTAGE 12 Vdc
- 2 CONNECTOR FOR DIGITAL INPUTS
- 3 LOAD CELL CONNECTOR
- 4 SERIAL CHANNEL CONNECTOR 1 RS 485

5.4 : Loading cell connector

To minimize electrical and radio interference, it is absolutely necessary that all connection cables between the instrument and transducer are shielded and that the entire system is connected to an excellent earth.

The instrument supplier can provide a specifically designed connection cable provided with double shielding to be soldered to the shield terminals and the earth.

For the cable protection shielding connection, refer to the figure below.

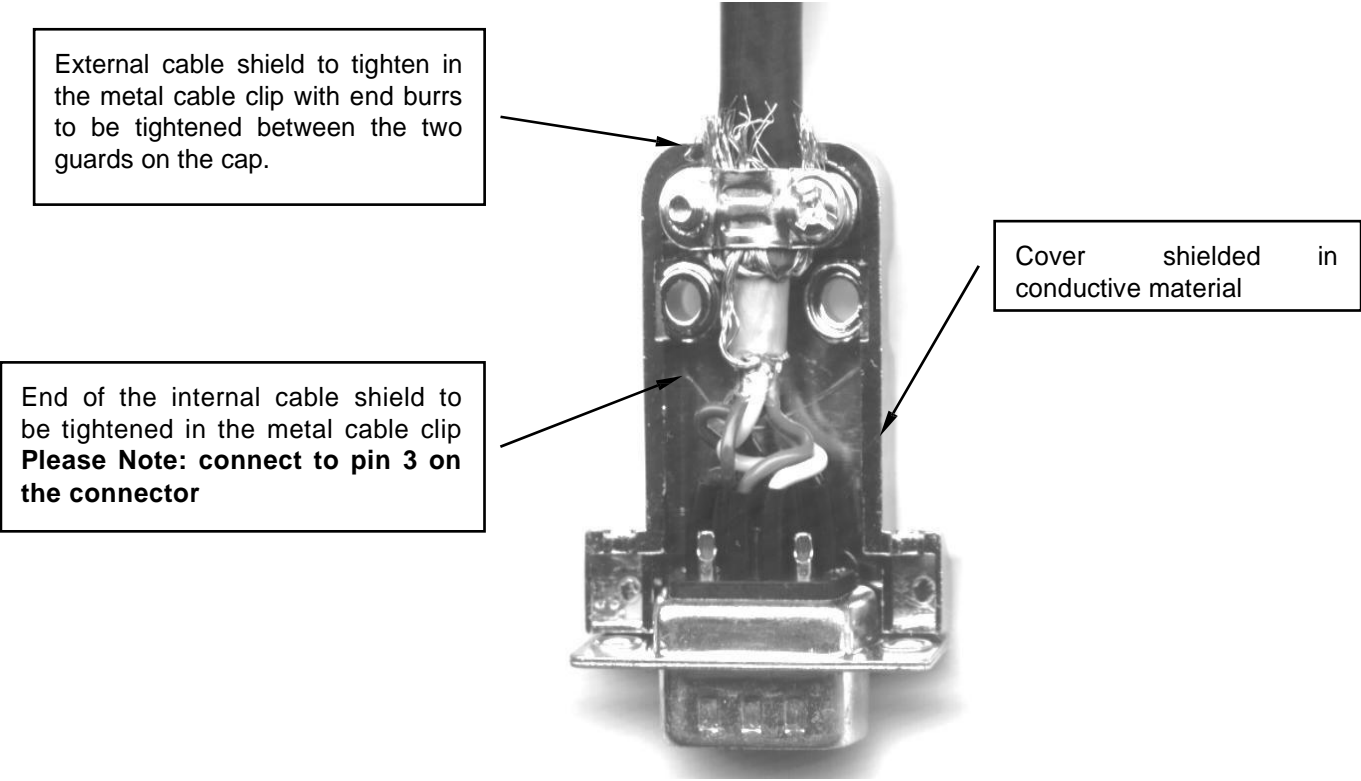

DB 9 male connector

Pin no.	meaning
1	- POWER SUPPLY
2	- SENSE
3	Shield
4	+ SENSE
5	+ POWER SUPPLY
7	- OUT
8	+ OUT

5.5 Metric plate location

